



GOVERNMENT OF INDIA
Ministry of Water Resources,
River Development and Ganga Rejuvenation
BRAHMAPUTRA BOARD

TENDER DOCUMENT

Group No. 1

NIT No. BB/EE/NBD/2016-17/08/1279 dated 19.12.2016

Repairing and extension of vehicle shed at Barsrakuchi Office
Complex, Brahmaputra Board, Nalbari

NALBARI DIVISION
NALBARI

No. BB/EE/NBD/2016-17/08/1279
 Government of India
 Ministry of Water Resources,
 River Development and Ganga Rejuvenation
 Office of the Executive Engineer
 Nalbari Division, Brahmaputra Board
 Email – bbnalbaridiv@gmail.com

Barsarkuchi, Nalbari - 781337
 Dated 19.12.2016

NOTICE INVITING TENDER

Sealed and separate Item Rate Tender in prescribed forms are invited on behalf of the Chairman, Brahmaputra Board from registered approved and eligible contractors of CPWD, Railways, P&T, MES and State Government Departments including PWD / Irrigation / Water Resources / Public Health Engineering Department for the following works –

Gr. No	Name of Work	Location	Estimated Amount (Rs.)	Earnest Money (Rs.)	Cost of Tender (Rs.)	Time of completion (Days)
1.	Repairing and extension of vehicle shed at Barsarkuchi Office Complex, Brahmaputra Board, Nalbari	Barsarkuchi, Nalbari	1,05,600.00	2112.00	500.00	15
2	Re-charging of Water Treatment Plant (Rapid Sand filter) with filter media and clearing of underground water sump at Barsarkuchi office complex, Brahmaputra Board, Nalbari	Barsarkuchi Nalbari	35,260.00	706.00	150.00	10
3	Construction of Flag hoisting platform at Barsarkuchi Office Complex, Brahmaputra Board, Nalbari	Barsarkuchi Nalbari	15,180.00	304.00	150.00	15
4	Repairing of existing Temporary Sentry House at the main gate at Barsarkuchi office complex, Brahmaputra Board, Nalbari	Barsarkuchi Nalbari	6,290.00	150.00	150.00	15

The intending Bidder may collect the detailed Tender Document containing terms & condition of contract from this office w.e.f **20.12.2016** on all working days up to **1500 Hours of 27.12.2016** on payment of the cost of Tender Document as shown above, in the shape of crossed IPO / Demand Draft / Bankers Cheque drawn in favour of the **Financial Adviser, Brahmaputra Board, Basistha, Guwahati - 29**. The Bidder should produce the original copies of up to date Registration Certificate, Income Tax Clearance Certificate / PAN card, VAT registration certificate at the time of procurement of Tender Document. The Bidder should submit requisite Earnest Money as shown above, in the shape of Fixed Deposit Receipt / Demand Draft / Deposit at Call Receipt drawn from any scheduled Bank guaranteed by the Reserve Bank of India and payable at Nalbari in favour of the Executive Engineer, Nalbari Division, Brahmaputra Board, Nalbari. Sealed Tender will be received in the office of the undersigned up to **1500 Hours of 29.12.2016** and will be opened on the same day at **1530 Hours** in presence of the Bidder or their authorised agent.

The Tender can be also be seen / downloaded from the website www.brahmaputraboard.gov.in. Bidders will have to deposit the cost of Tender Documents, if downloaded, at the time of submission of Tender Document.

The undersigned reserves the right to reject any or all tenders without assigning any reason thereof and is not bound to accept the lowest tender.

Executive Engineer
Nalbari Division

Copy to :-

1. The Deputy Commissioner, Nalbari District, Nalbari for information and wide circulation.
2. The Superintending Engineer, Nalbari Circle, Brahmaputra Board, Nalbari for favour of kind information.
3. The Executive Engineer, Water Resources Department, Government of Assam, Nalbari for wide circulation.
4. The Asstt. Executive Engineer, Nalbari Sub-Division-I / Nalbari Sub-Division-II / Rangia Sub-Division, Brahmaputra Board, Nalbari / Rangia for information and wide circulation.
5. The In-charge, I.T. Cell, Brahmaputra Board, Basistha, Guwahati-29 for information and publication through Brahmaputra Board website.
6. Notice Board.

DETAILED TERMS & CONDITIONS

1. **Purchase of Tender Document** : The Non-transferable Tender Document can be obtained from the office of the Executive Engineer, Nalbari Division, Brahmaputra Board, Nalbari on payment of cost of tender document as per requirement in the NIT in the shape of crossed IPO/ Demand draft/ Banker cheque drawn in favour of the Financial Adviser, Brahmaputra Board, Basistha, Guwahati-29 on all working days from 1100 hours to 1500 hours. The bidder should produce original copies of up to date Registration Certificate, Income Tax Clearance Certificate / PAN card, VAT registration certificate at the time of procurement of Tender Document.
2. **Earnest Money** : The Tender shall be submitted in sealed cover along with Earnest money as stated above for each group in the form of Fixed Deposit Receipt / Demand Draft / Deposit at Call Receipt drawn from any scheduled Bank guaranteed by the Reserve Bank of India and payable at Nalbari in favour of the Executive Engineer, Nalbari Division, Brahmaputra Board, Nalbari.

The Earnest Money of the successful Bidder will be retained and will form a part of the Security Deposit till completion of the work. The Earnest Money of the unsuccessful Bidder will be returned after finalization of the Bid.
3. **Quoted Rate** : The rate shall be quoted Item wise as per schedule inclusive of all taxes like Income Tax, Value Added Tax (VAT), Forest Royalty or any other taxes as applicable. The rate should be quoted both in figure and words. Overwriting should be avoided and the bidder shall duly initial in the corrections made, if any. In case of any discrepancy in figure and word, rate quoted in word will be considered for evaluation.
4. **Validity of Tender** : The validity of the Tender is 30 (thirty days) from the date of opening of Tender.
5. **Time of completion** : The completion time for the work is as per NIT from the 10th day of the issue of the formal work order / written order to commence the work.
6. **Tax deduction** : The necessary tax like Income Tax, VAT, or any other tax, if applicable will be deducted from the bill value in due course of time as per rule. Contractor shall submit documents of forest royalty, if any.
7. **Submission of Tender** : The complete Tender Document along with self attested copies of up to date Registration Certificate, Income Tax Clearance Certificate / PAN card, VAT registration certificate, cost of Tender (if downloaded) and Earnest Money as per terms and condition stipulated in Tender Document should be submitted in a Sealed Cover indicating the name of work, NIT No. etc. and to be dropped in the Tender Box kept in the office of the Executive Engineer on or before the scheduled date and time. The Sealed Envelope containing complete Tender Document is to be addressed to the Executive Engineer, Nalbari Division, Brahmaputra Board, Nalbari. All pages of the Tender Document should be duly signed by the Bidder.
8. **Rejection of Quotation** : The Officer inviting Tender reserves the right of rejecting all or any Tenders without assigning any reason thereof and is not bound to accept the lowest Tender. Tenders which do not fulfill the prescribed terms and conditions of the

contract or incomplete in any respect are liable to be rejected. Tenders which are not as per terms and conditions or contain too much error / corrections and / or absurd rates are also liable for rejection without assigning any reason. Canvassing in connection with the Tender is strictly prohibited and the Tenders submitted by the Bidder who resort to canvassing will be liable for rejection.

9. **Opening of Tender** : The Tender will be open on the Scheduled Date, time and place as mentioned in Notice Inviting Tender. If the Schedule Date of opening coincides with a Government Holiday, then the Tender will be opened on the next working day. The interested Bidder or their authorized agent / representative may present at the time of opening of the Tender.
10. **Acceptance of Tender** : The acceptance of the Tender will rest with the Executive Engineer, Nalbari Division, Brahmaputra Board, Nalbari and does not bind him to accept the lowest Rates.

Executive Engineer
Nalbari Division

Name of Work :- Repairing and extension of vehicle shed at Barsrakuchi Office Complex, Brahmaputra Board, Nalbari

SCHEDULE OF ITEMS

Item No.	Description of Items of work	Unit	Qty.	Rates in figure	Rate in words
1	Earthwork in excavation for foundation trenches of walls, retaining walls, footings of column, steps, septic tank, etc. including refilling (return filling) the quantity as necessary after completion of work, breaking clods in return filling, dressing, watering and ramming etc. and removal of surplus earth with all lead and lifts as directed and specified in the following classification of soils including bailing out water where necessary as directed and specified.	Cum	2.90		
2	Providing soling in foundation and under floor with stone/best quality picked jhama brick, sand packed and laid to level and in panel after preparing the subgrade as directed including all labour and material sand if necessary dewatering, complete (a) Brick Flat oling.	Sqm	60.00		
3	Plain cement concrete works with coarse aggregate of sizes 13 mm to 32 mm in foundation bed for footing steps, walls, brick works, etc. as directed and specified including dewatering if necessary, and curing complete (shuttering where necessary shall be measured and paid separately)	Cum	0.67		
4	Brickwork in cement mortaar with 1st class bricks including racking out joints and curing complete as directed (l) In Sub-structure upto plinth level including dewatering if necessary (a) In proportion 1:4	Cum	2.44		
5	Earth/sand filling in plinth in layers not more than 150 mm thick including necessary carriage, watering, ramming, etc. complete as directed and specified including payment of land compensation, forest royalty, sales tax and other duties and taxes as may be necessary (c) With river sand or silt (predominantly non plastic) by truck carriage including loading and unloading	Cum	54.00		

Item No.	Description of Items of work	Unit	Qty.	Rates in figure	Rate in words
6	Providing undressed wood work in roof truss, rafter, purlin, tie and the like including hoisting and fixing in position with necessary spikes, nails including MS straps with bolt and bnuts etc. complete with kiricide oiling two coats to all timber members and two coats of anticorrosive paint to MS straps (MS flats, angle cleats, and bolt and nuts required for flat and angle cleats wherever used shall be measured and paid separately) (b) With Hollock/Sundi/Sam	Cum	0.39		
7	Labour for fitting and fixing Galvd corrugated iron roofing including supplying and fixing with new galvd screw, J hook, bolts nuts, washer etc. complete a s directed	Sqm	44.64		
8	Supplying fitting and laying the Ready made RCC precast post of 0.127 m x 0.127 m x 3.60 m	No.	6		
9	Renewing/providing single tarja enclosure walls made of Muli/Jati bamboo double tarja enclosur walls with baruah/Bhaluka bamboo 87 mm to 100 mm dia, 1800 mm apart and 1800 mm height (approx) above ground and driven 750 mm below ground and half Muli/jati bamboo on both the faces 4 lines, including supplying and tying with galvd. wire complete as directed	Sqm	54.30		

Signature of bidder (s)

PLAN

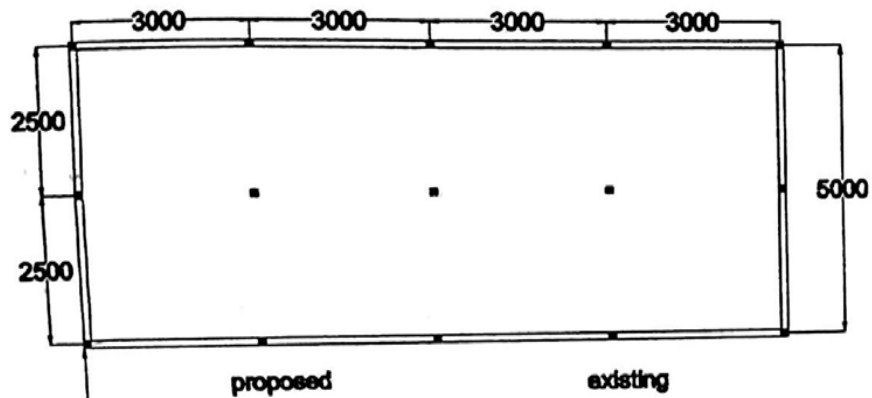

EARTH FILLING

10000

New Approach

Existing Approach

← ROAD →

CGI sheet roofing

75x75 purlin

75x100 post plate

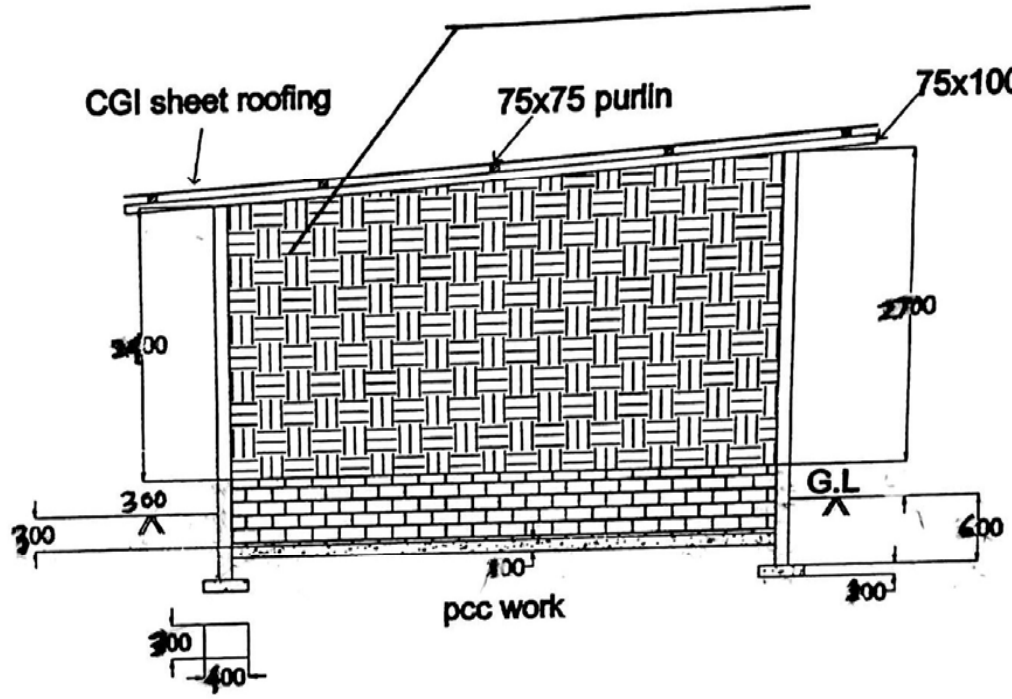

SIDE VIEW

**** ALL DIMENSIONS ARE IN MM
SCALE=1/00**

**GOVT OF INDIA
MINISTRY OF WATER RESOURCE
BRAHMAPUTRA BOARD**

**DRAWING FOR REPAIRING AND EXTENTION OF VEHICLE
GARAGE AT BARBARUKLICH OFFICE COMPLEX,
BRAHMAPUTRA BOARD, HALBARI**

DRAWN BY	CHECKED BY	SUBMITTED BY
G	[Signature]	